



Level



Pressure



Flow



Temperature

Liquid  
Analysis

Registration

Systems  
Components

Services



Solutions

Technical Information

## Memograph M

Graphic Data Manager RSG40

Record, visualize, analyze and communicate

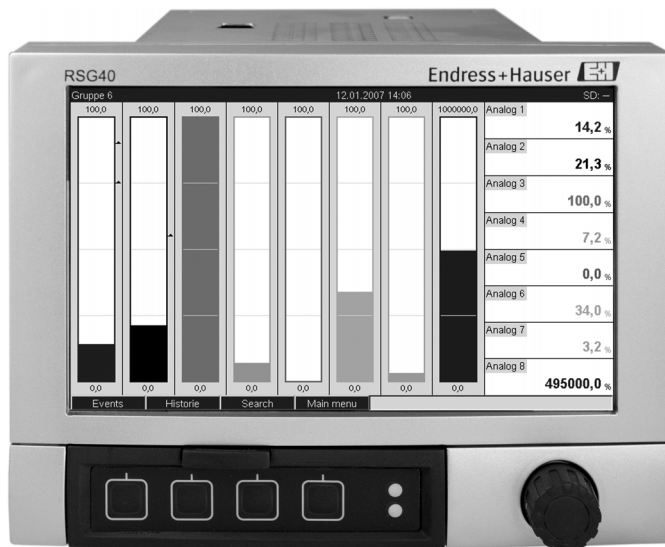

### Application

The graphic data manager Memograph M provides information on all the relevant process variables. Measured values are recorded correctly, limit values are monitored and measuring points analyzed. The data are stored in the 256 MB internal memory and also on an SD card or USB stick. Memograph M boasts a modular design, intuitive operation and a comprehensive security concept. The ReadWin® 2000 PC software is part of the standard package and is used for configuring, visualizing and archiving the data captured.

The solution for all your tasks. For example, for:

- Process measuring technology
- Power stations and energy supply
- Food and pharmaceutical industry
- Environmental and climate measuring technology
- Quality assurance and production
- Plant and apparatus engineering and construction
- Testing bays and laboratory applications



### Your benefits

- **Visual:** 7" TFT display as onsite display for optimum readability
- **Fast:** 100 msec scan rate for all channels, high-speed memory cycle 100 msec
- **Secure:** Security package with person-specific access authorization and electronic signature (FDA 21 CFR 11)
- **Modular:** Easy retrofitting to up to 20 universal inputs and 14 digital inputs or 12 relays
- **Flexible:** Free choice of display mode. Completely new: instrument and circular chart display
- **Limitless:** Integrated Web server, fieldbus (Profibus, Modbus), common standard protocols and interfaces such as USB, TCP/IP, OPC and Ethernet are supported
- **Informative:** Event search, automatic signal analysis
- **Practicable:** Installation depth 158 mm, plastic front IP65, NEMA4
- **Clear:** Alarm management with all active, confirmed and historical alarms

## Function and system design

### Measuring principle

Electronic acquisition, display, recording, analysis, remote transmission and archiving of analog and digital input signals.

### Measuring system

Multichannel data recording system with multicolored TFT display (170 mm/7" screen size), galvanically isolated universal inputs (U, I, TC, RTD, pulse, frequency), digital input, transmitter power supply, limit relay, communication interfaces (USB, Ethernet, RS232/485), internal SD memory, external SD card and USB stick. 100 ms scan rate for all channels. ReadWin® 2000 PC software for comprehensive device configuration and data evaluation.



#### Note!

The number of inputs, outputs and relays contained in the basic device can be individually extended using a maximum of five plug-in cards. The Memograph M provides power directly to connected two-wire transmitters. The device is configured and operated via 4 keys and the navigator (jog/shuttle dial) by means of the interface and ReadWin® 2000 PC software or an external keyboard. The online help makes onsite operation easier. Measured values, events and alarms are coded in accordance with the serial protocol and then transmitted.

### Block circuit diagram

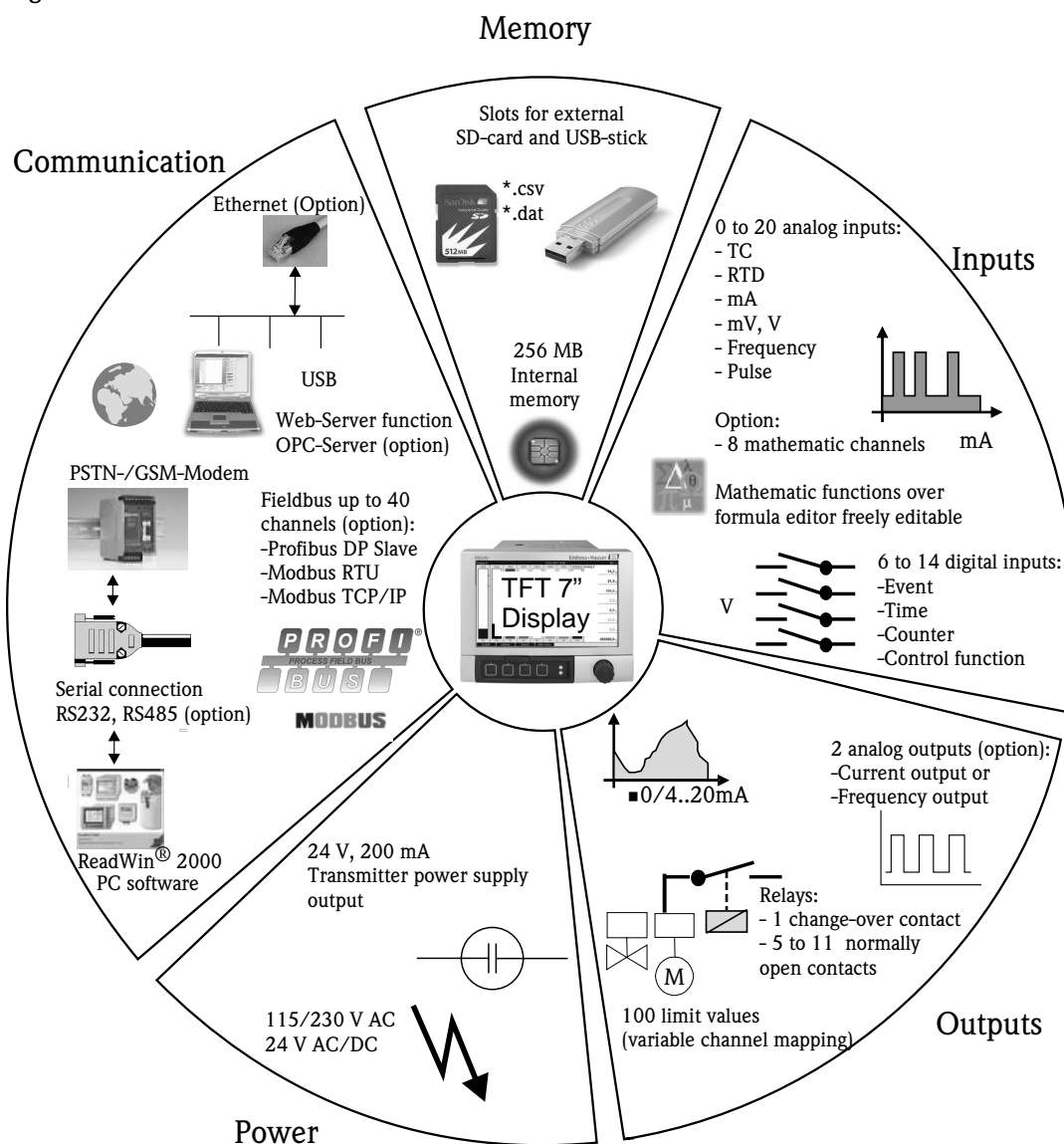

This block circuit diagram provides a rough overview of the functions.

**Application packages/  
software options**

User-friendly function extension (even subsequently) through the online activation of all the optional instrument functions. The following software options are available:

Functions	Software package	
	Standard incl. security package	Mathematics package
Integration/totalizers	✓	✓
Min./max. value, average value recording	✓	✓
Signal analysis: day, week, month, year, external (digital input)	✓	✓
Event messages	✓	✓
Operation time counter	✓	✓
Text entry/comments	✓	✓
Change language	✓	✓
Time synchronization	✓	✓
Screensaver	✓	✓
Web server/e-mail	✓	✓
Linearization	✓	✓
External keyboard	✓	✓
Access protection through release code	✓	✓
Mathematics functions via formula editor		✓
Logic operations		✓
User administration 21 CFR Part 11	✓	✓

## Input

### Analog multifunction inputs

#### Number

Standard version without universal inputs.  
Optional multifunction input cards (slot 1-5) each with 4 universal inputs (4/8/12/16/20).

#### Function

You can choose between the measured variables U, I, RTD, TC, pulse input or frequency input for each universal input.

#### Measured variable, measuring range

To IEC 60873-1:

An additional display error of  $\pm 1$  digit is permitted for every measured value.

Measuring ranges which can be selected per channel:

Measured variable	Measuring range	Maximum measured error of measuring range (oMR)	Input resistance
<b>Current (I)</b>	0 to 20 mA 0 to 5 mA 4 to 20 mA Overrange: up to 22 mA	$\pm 0.10\%$ oMR	Load: $\leq 50$ Ohm
<b>Voltage (U) &gt; 1 V</b>	0 to 10 V 0 to 5 V $\pm 10$ V $\pm 30$ V	$\pm 0.10\%$ oMR	$\geq 1$ MOhm
<b>Voltage (U) <math>\leq 1</math> V</b>	0 to 1 V $\pm 1$ V $\pm 150$ mV	$\pm 0.10\%$ oMR	$\geq 2.5$ MOhm
<b>Resistance thermometer (RTD)</b>	Pt100: -200 to 850 °C (-328 to 1562 °F) (IEC751, GOST) Pt100: -200 to 649 °C (-328 to 1200.2 °F) (JIS1604) Pt500: -200 to 850 °C (-328 to 1562 °F) (IEC751) Pt500: -200 to 649 °C (-328 to 1200 °F) (JIS1604) Pt1000: -200 to 600 °C (-328 to 1112 °F) (IEC751, JIS1604)	4-wire: $\pm 0.10\%$ oMR 4-wire: $\pm 0.10\%$ oMR 3-wire: $\pm (0.10\% \text{ oMR} + 0.8 \text{ K})$ 3-wire: $\pm (0.10\% \text{ oMR} + 0.8 \text{ K})$ 2-wire: $\pm (0.10\% \text{ oMR} + 1.5 \text{ K})$	
	Cu100: -200 to 200 °C (-328 to 392 °F) (GOST) Cu50: -200 to 200 °C (-328 to 392 °F) (GOST) Pt50: -200 to 850 °C (-328 to 1562 °F) (GOST)	4-wire: $\pm 0.20\%$ oMR 3-wire: $\pm (0.20\% \text{ oMR} + 0.8 \text{ K})$ 2-wire: $\pm (0.20\% \text{ oMR} + 1.5 \text{ K})$	
<b>Thermocouples (TC)</b>	Type J (Fe-CuNi): -210 to 1200 °C (-346 to 2192 °F) (IEC581-1) Type K (NiCr-Ni): -270 to 1372 °C (-454 to 2501.6 °F) (IEC581-1) Type T (Cu-CuNi): -270 to 400 °C (-454 to 752 °F) (IEC581-1) Type N (NiCrSi-NiSi): -270 to 1300 °C (-454 to 2372 °F) (IEC581-1) Type L (Fe-CuNi): -200 to 900 °C (-328 to 1652 °F) (DIN43710) Type L (Fe-CuNi): -200 to 659 °C (-328 to 1218.2 °F) (GOST)	$\pm 0.10\%$ oMR as of -100 °C (-148 °F) $\pm 0.10\%$ oMR as of -130 °C (-202 °F) $\pm 0.10\%$ oMR as of -200 °C (-328 °F) $\pm 0.10\%$ oMR as of -100 °C (-148 °F) $\pm 0.10\%$ oMR as of -100 °C (-148 °F) $\pm 0.10\%$ oMR as of -100 °C (-148 °F)	$\geq 1$ MOhm
	Type D (W3Re-W25Re): 0 to 2315 °C (32 to 4199 °F) (ASTME998) Type C (W5Re-W26Re): 0 to 2315 °C (32 to 4199 °F) (ASTME998) Type B (Pt30Rh-Pt6Rh): 0 to 1820 °C (32 to 3308 °F) (IEC581-1) Type S (Pt10Rh-Pt): -50 to 1768 °C (-58 to 3214.4 °F) (IEC581-1) Type R (Pt13Rh-Pt): -50 to 1768 °C (-58 to 3214.4 °F) (IEC581-1)	$\pm 0.15\%$ oMR as of 500 °C (932 °F) $\pm 0.15\%$ oMR as of 500 °C (932 °F) $\pm 0.15\%$ oMR as of 600 °C (1112 °F) $\pm 0.15\%$ oMR as of 100 °C (212 °F) $\pm 0.15\%$ oMR as of 100 °C (212 °F)	$\geq 1$ MOhm
<b>Pulse input (I)</b>	Min. pulse length 30 $\mu$ s, max. 13 kHz		
<b>Frequency input (I)</b>	0 to 10 kHz, overrange: to 12.5 kHz	$\pm 0.01\%$ oMR	Load: $\leq 50$ Ohm

#### Maximum input load

Limit values for input voltage and input current as well as cable open circuit detection/line influence/temperature compensation:

Measured variable	Limit values (steady-state, without destroying input)	Cable open circuit detection/line influence/temperature compensation
<b>Current (I)</b>	Maximum permitted input voltage: 2.5 V Maximum permitted input current: 50 mA	4 to 20 mA range with disengageable cable open circuit detection as per NAMUR NE43. The following error ranges apply if NE43 is activated: ≤ 3.8 mA: underrange (display shows: vvvvvv) ≥ 20.5 mA: overrange (display shows: ^^^^^^) ≤ 3.6 mA or ≥ 21.0 mA: cable open circuit (display: ---)
<b>Pulse, frequency (I)</b>	Maximum permitted input voltage: 2.5 V Maximum permitted input current: 50 mA Minimum pulse length: 30 μs Maximum 13 kHz	No cable open circuit monitoring
<b>Voltage (U) &gt; 1 V</b>	Maximum permitted input voltage: 35 V	
<b>Voltage (U) ≤ 1 V</b>	Maximum permitted input voltage: 24 V	
<b>Resistance thermometer (RTD)</b>	Measuring current: ≤ 1 mA	Maximum barrier resistance (or line resistance): Max. 200 Ohm (4-wire) Max. 40 Ohm (3-wire)  Maximum influence of barrier resistance (or line resistance) for Pt100, Pt500 and Pt1000: 4-wire: ±0.0002%/Ohm, 3-wire: ±0.002%/Ohm  Maximum influence of barrier resistance (or line resistance) for Pt50, Cu100 and Cu50: 4-wire: ±0.0006%/Ohm, 3-wire: ±0.006%/Ohm
<b>Thermocouples (TC)</b>	Maximum permitted input voltage: 24 V	Cable open circuit detection from 50 kOhm Influence of line resistance in event of break detection: < 0.001%/Ohm Error, internal temperature compensation: ≤ 2 K

**Scan rate**

All channels are scanned within 100 ms.

**Converter resolution**

24 bit

**Totalization**

The interim value, daily value, weekly value, monthly value, annual value and overall value can be determined (13-digit, 64 bit).

**Digital inputs**

**Number**

Standard version: 6 digital inputs  
Optional digital card (slot 5): 8 additional digital inputs

**Input level**

To IEC 61131-2:  
Logical "0" (corresponds to -3 to +5 V), activation with logical "1" (corresponds to +12 to +30 V)

**Input frequency**

Max. 25 Hz

**Pulse length**

Min. 20 ms

**Input current**

Max. 2 mA

**Input voltage**

Max. 32 V (steady-state, without destroying input)

**Selectable functions**

Control input, ON/OFF message, pulse counter (13-digit, 64 bit), operating time, message+operating time, quantity from time.

Functions of the control input: start recording, screensaver on, block setup, block keyboard/navigator, time synchronization, change group, limit value monitoring on/off, individual LV on/off, start/stop evaluation.

## Output

**Auxiliary voltage output**

The auxiliary voltage is provided to activate the digital input (or the sensors) with floating contacts and is galvanically isolated from the system and the inputs (testing voltage 500 V). The ground of the auxiliary voltage and the ground of the digital input are electrically interconnected.

**Output voltage:**

Approx. 24 V DC, max. 28 V

**Output current:**

Maximum 200 mA, short-circuit proof, not stabilized

**Relay outputs**

Standard version (power supply slot): 1 alarm relay with changeover contact, 5 relays with NO contact e.g. for limit value alarms (can be configured as NC contact).

Optional digital card (slot 5): 6 additional relays with NO contact e.g. for limit value alarms (can be configured as an NC contact).



Note!

It is not permitted to mix low voltage and safety extra low voltage (do not mix SELV circuits and low voltage).

**Response time:**

max. 400 ms

**Maximum DC contact load:**

50 V / 300 mA (steady-state, without destroying input)

**Maximum AC contact load:**

230 V / 3 A (steady-state, without destroying input)

**Analog and pulse outputs****Number:**

Optional digital card (slot 5): 2 analog outputs which can be operated as current or pulse outputs.

**Analog output (current output):**

Output current: 0/4 to 20 mA with 10 % overrange

Max. output voltage: approx. 16 V

Accuracy:  $\leq 0.1$  % of output range

Temperature drift:  $\leq 0.015$  %/K

Resolution: 13 bit

Load: 0 to 500 Ohm

Error signal to NAMUR NE43: 3.6 mA or 21 mA can be configured

**Digital output (pulse output):**

Output voltage as per DIN 19240:

$\leq 5 \text{ V}$  corresponds to LOW  
 $\geq 12 \text{ V}$  corresponds to HIGH  
 Short-circuit proof (maximum 25 mA)

Frequency: 0 to 1 kHz  
 Pulse width: 1 to 1000 ms  
 Accuracy:  $\leq 0.1 \%$  of output range  
 Temperature drift:  $\leq 0.1 \%/^{\circ}\text{C}$   
 Load:  $\geq 1 \text{ k}\Omega$

---

**Galvanic isolation**

All the inputs and outputs are galvanically isolated from one another and tested with the following testing voltages:

	<b>Relay</b>	<b>Digital in</b>	<b>Analog in</b>	<b>Analog out</b>
<b>Relay</b>	2.3 kV	2.3 kV	2.3 kV	2.3 kV
<b>Digital in</b>	2.3 kV	500 V	500 V	500 V
<b>Analog in</b>	2.3 kV	500 V	500 V	500 V
<b>Analog out</b>	2.3 kV	500 V	500 V	500 V

# Power supply / terminal diagram

## Electrical connection (wiring diagram)

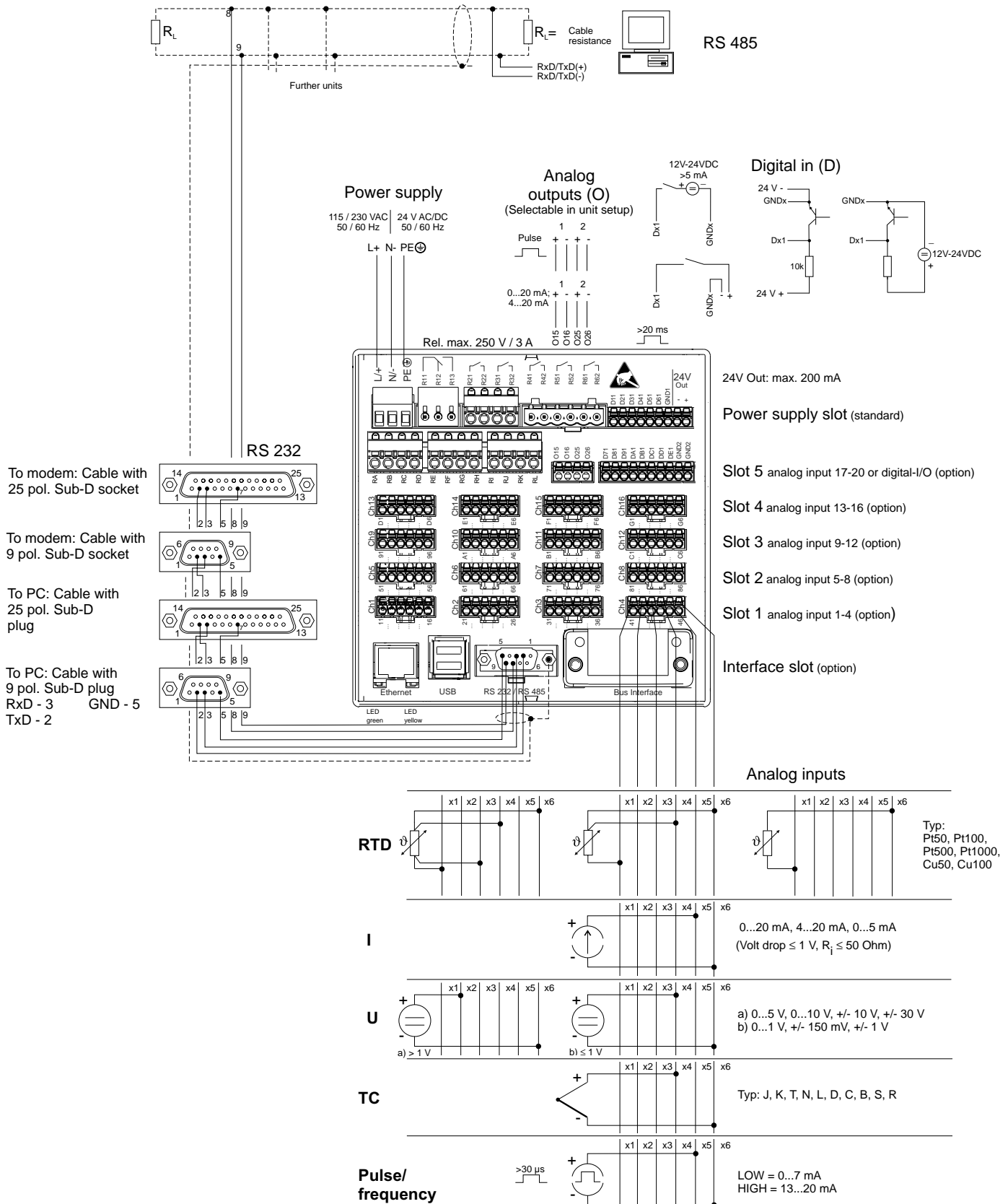

<b>Supply voltage</b>	Low voltage power unit: 115 / 230 V <sub>AC</sub> Extra-low voltage power unit: 24 V <sub>AC/DC</sub>
<b>Frequency</b>	Nominal frequency: 50 / 60 Hz
<b>Cable specification</b>	Screw or spring terminal blocks with reverse polarity protection: Wire cross-section, digital I/O and analog inputs: max. 1.5 mm <sup>2</sup> (14 AWG) (spring terminals) Wire cross-section, power supply: max. 2.5 mm <sup>2</sup> (13 AWG) (screw terminals) Wire cross-section, relays: max. 2.5 mm <sup>2</sup> (13 AWG) (spring terminals)
<b>Power consumption</b>	115 / 230 V: max. 40 VA 24 V: max. 40 VA

**Connection data interfaces, communication, operation**

**USB ports:**

*USB on the front of the device*

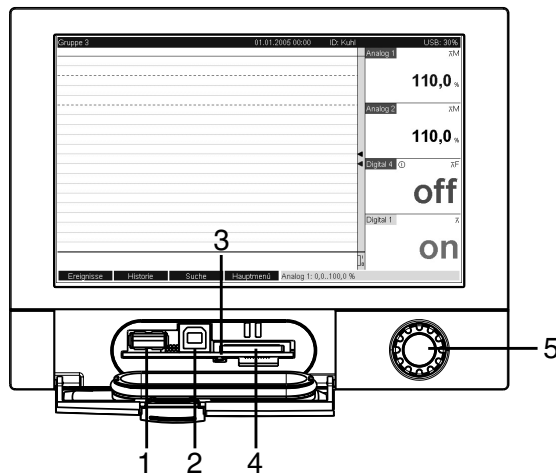

*Front of device with open flap/keyboard*

- 1: USB A socket "host" e.g. for USB memory stick
- 2: USB B socket "function" e.g. for laptop
- 3: LED at SD slot. Yellow LED lit when the device writes to the SD card or reads it.
- 4: Slot for SD card
- 5: Navigator

**1 x USB connection type A (host)**

A compatible USB 2.0 connection is available on a shielded USB A socket at the front of the device. An USB stick as a memory medium can be connected to this port.

**1 x USB connection type B (function)**

A compatible USB 2.0 connection is available on a shielded USB B socket at the front of the device. This can be used to connect the device for communication with a laptop for example.

*USB on the rear of the device (optional)*

**2 x USB connection type A (host) (interface slot, optional)**

Two compatible USB 2.0 connections are available on shielded USB A sockets at the rear of the device. An USB stick as a memory medium can be connected to these ports.



Note!

- The USB 2.0 connections are compatible with USB 1.1, i.e. communication is possible.
- The assignment corresponds to a standards-compliant USB port such that a shielded standard cable with a maximum length of 3 meters (9.8 ft) can be used here.
- Several USB sticks cannot be operated at the same time. The USB stick attached first has priority.

**Ethernet interface (interface slot, optional):**

An IEEE 802.3-compatible connection is available on a shielded RJ45 plug connector on the rear of the device as the network connection. This can be used to connect the device with a hub or switch to devices in an office environment. For safe spacing distances, the office equipment standard EN 60950 must be observed. The assignment corresponds to a standards-compliant MDI port (AT&T258) such that a shielded 1:1 cable with a maximum length of 100 meters (328 ft) can be used here. The Ethernet port is designed as 10/100-BASE-T. Direct connection to a PC is possible with a crossover cable. Half-duplex and full-duplex data transfer is supported.

The device can be used in the network as a "Web server". Two Ethernet function LEDs on the rear of the device.

**Serial RS232/RS485 interface (interface slot, optional):**

A combined RS232/RS485 connection is available on a shielded SUB D9 socket at the rear of the device. This can be used for data or program transfer, to connect an RS232 barcode reader or as a modem connection. For communication via modem, we recommend an industrial modem with a watchdog function. The Modbus protocol (master and slave) is available. RTU (remote terminal unit) is used as the transmission mode.

The following baudrates are supported: 1200, 2400, 4800, 9600, 19200, 38400, 57600, 115200

Max. line length with shielded cable: 2 m (6.6 ft) (RS232) or 1000 m (3281 ft) (RS485)

Both interfaces are galvanically isolated from the system.

The RS232/RS485 interfaces cannot be used simultaneously.

**Remote interrogation with analog or GSM wireless modem:**

- Analog modem:

An analog modem (e.g. Devolo MicroLink 56ki or WESTERMO), which is connected to the RS232 interface with a special modem cable (see Accessories), is recommended for industry.

- GSM wireless modem:

A GSM wireless modem (e.g. Siemens TC35i, incl. antenna and power unit), which is connected to the RS232 interface with a special modem cable (see Accessories), is recommended. Important: The wireless modem needs a SIM card and data transfer subscription. In addition, it must be possible to deactivate the PIN prompt.

**Bus interface (interface slot, optional)**

- PROFIBUS-DP slave (pending):

The device can be integrated into a fieldbus system as per the PROFIBUS-DP standard by means of the PROFIBUS-DP interface. Up to 40 analog inputs and 14 digital inputs can be transmitted via PROFIBUS-DP and stored in the device. For bidirectional communication in cyclic data transfer.

Baudrate: maximum 12 Mbit/s

- Modbus RTU slave (pending):

Up to 40 analog inputs and 14 digital inputs can be transmitted via Modbus and stored in the device.

- Ethernet Modbus TCP slave (pending):

Connection to SCADA systems (Modbus master). Up to 40 analog inputs and 14 digital inputs can be transmitted via Modbus and stored in the device.

## Performance characteristics

---

**Reference operating conditions**

Ambient temperature: 25 °C ± 5 K (77 °F ± 9 °F)  
Air humidity: 55 % ± 10 % r.h.

---

**Maximum measured error**

(See Input)

---

**Temperature drift**

Cu100, Cu50 and Pt50: max. ± 0.02 %/K (of measuring range)  
All other ranges: max. ± 0.01 %/K (of measuring range)

---

**Long-term drift**

To IEC 61298-2: max. ± 0.01 %/month (of measuring range)

## Installation

### Orientation

Operating position as per DIN 16 257, NL 90 ± 30°

### Installation instructions

### Panel cutout and installation / design, dimensions:

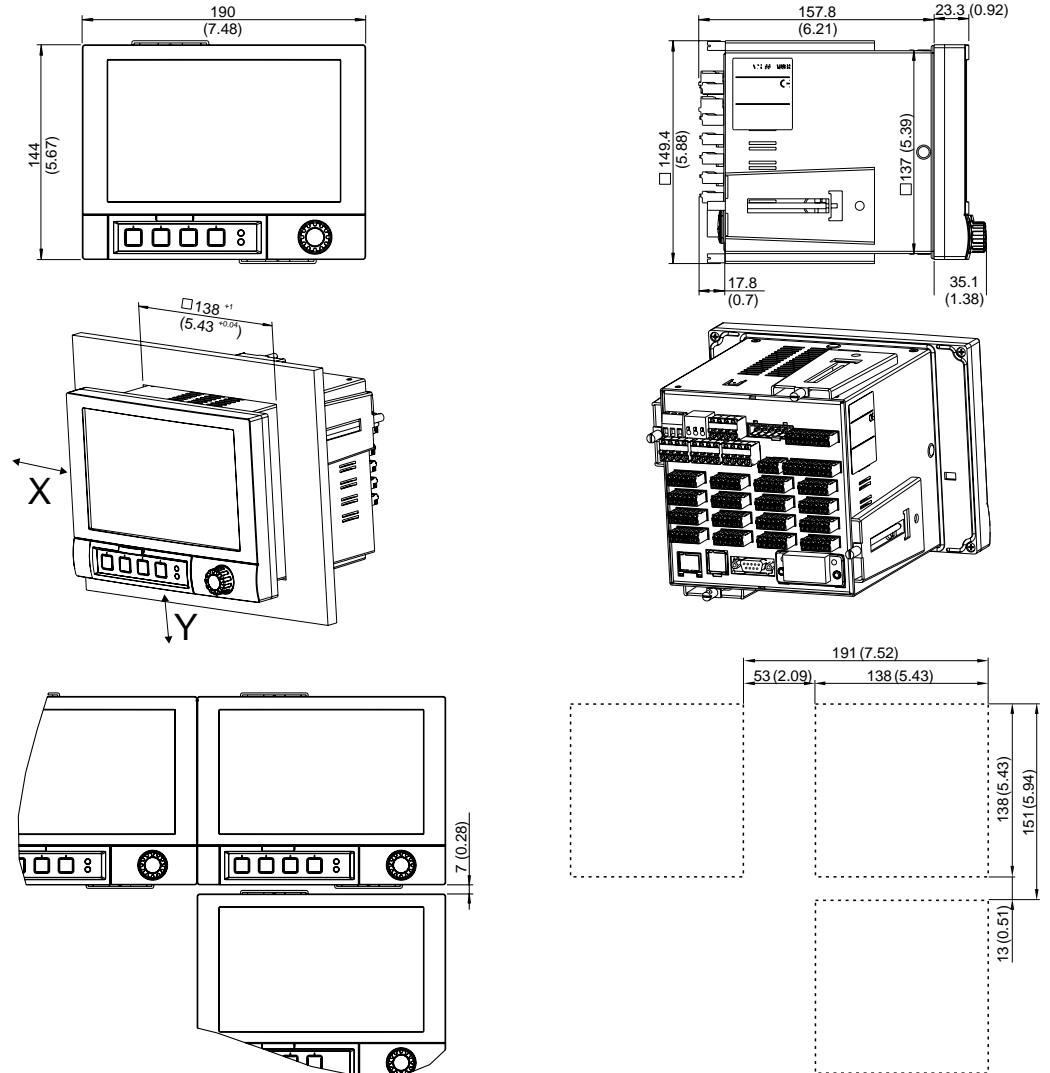

All dimensions in mm or (inch)

- Installation depth: approx. 158 mm (6.22") (incl. terminals and fastening clips)
- Panel cutout: 138<sup>+1</sup> x 138<sup>+1</sup> mm (5.43<sup>+0.04</sup> x 5.43<sup>+0.04</sup>)
- Panel thickness: 2 to 40 mm (0.08 to 1.58")
- Max. viewing angle range: from the display central axis 50° in all directions
- Securing to DIN 43 834



#### Note!

- A distance of min. 7 mm (0.28 inch) between the devices has to be observed if aligning the devices in the Y-direction (vertically above one another).
- The devices can be arranged horizontally beside one another in the X direction without any spacing between the devices.
- The grid dimension of the panel cutouts for multiple devices must be min. 191 mm (7.52") horizontally and min. 151 mm (5.94") vertically (tolerance not considered).

## Environment

<b>Ambient temperature range</b>	-10 to 50 °C (14 to 122 °F)
<b>Storage temperature</b>	-20 to +60 °C (-4 to 140 °F)
<b>Climate class</b>	To IEC 60654-1: B1
<b>Degree of protection</b>	Front-panel IP65 (IEC 60529, Cat. 2) NEMA 4 Rear-panel IP20 (IEC 60529, Cat. 2)
<b>Electrical safety</b>	IEC 61010-1, protection class I Low voltage: overvoltage category II Environment < 3000 m (< 9843 ft) above MSL (mean sea level)
<b>Electromagnetic compatibility (EMC)</b>	<p><b>Interference immunity:</b></p> <p>To IEC 61326 (industrial environment) and NAMUR NE21:</p> <ul style="list-style-type: none"> <li>■ ESD (electrostatic discharge): IEC 61000-4-2 severity 3 (6/8 kV)</li> <li>■ HF field (electromagnetic interference fields): IEC 61000-4-3: severity 3 (10 V/m)</li> <li>■ Burst (quick transient disturbance variables): IEC 61000-4-4 severity 3 (1 kV signal, 2 kV power supply)</li> <li>■ Surge on power line: IEC 61000-4-5: 2 kV asymmetrical, 1 kV symmetrical</li> <li>■ Surge on signal line: IEC 61000-4-5: 1 kV asymmetrical (with external protection element)</li> <li>■ Conducted HF: IEC 61000-4-6: 150 kHz to 80 MHz, 10 V</li> <li>■ Power failure: IEC 61000-4-11 (&gt; 20 ms/0%)</li> <li>■ Voltage variation: IEC 61000-4-11 (40% / 0%)</li> </ul> <p><b>Emission:</b></p> <p>To IEC 61326: Class A (operation in industrial environment)</p> <p><b>Interference voltage:</b></p> <p>Power cable: To CISPR 16-1/-2: Class A</p> <p><b>Interference current:</b></p> <p>Ethernet cable: To EN 50022: Class A</p> <p><b>Interference field intensity:</b></p> <p>Housing/all connections: To CISPR 16: Class A</p> <p><b>Interference voltage suppression:</b></p> <ul style="list-style-type: none"> <li>■ Common mode interference voltage suppression: IEC 61298-3: Analog inputs: 80 dB at 60 V and 50 Hz / 60 Hz</li> <li>■ Push-pull interference voltage suppression: IEC 61298-3: Analog inputs: 40 dB at 50 Hz / 60 Hz, for measuring range/10</li> </ul>

## Mechanical construction

<b>Design, dimensions</b>	See Installation
<b>Weight</b>	<ul style="list-style-type: none"> <li>■ Panel-mounted instrument, maximum configuration: approx. 2 kg (4.4 lb)</li> </ul>
<b>Materials</b>	<p>Front (front part incl. display panel): transparent plastic (PC UL94-V2) (border area painted)</p> <p>Flap (front): plastic (ABS UL94-V2)</p> <p>Membrane keypad: polyester (PC-ABS UL94-V2)</p> <p>Jog/shuttle dial ("navigator"): plastic (ABS UL94-V2)</p> <p>Intermediate frame (front to panel): plastic (PA6-GF15 UL94-V2)</p> <p>Casing: St 12 ZE (galvanized sheet steel)</p>



Rear panel: St 12 ZE (galvanized sheet steel)

Note!

All materials are free from silicone.

## Human interface

### Display elements

**Type:**

Wide-screen TFT color graphic display

**Size (Screen size):**

178 mm (7")

**Resolution:**

Wide VGA 384,000 pixels (800 x 480 pixels)

**Background illumination:**

50,000 h half value time (= half brightness)

**Number of colors:**

262,000 viewable colors, 256 colors used

**Viewing angle:**

Max. viewing angle range: from the display central axis 50° in all directions

**Screen display:**

- Users can choose between black or white for the background color
- Active channels can be assigned to up to 10 groups. For the purposes of clear identification, these groups are given a name e.g. "Temperatures boiler 1" or "Daily average values of all boilers"
- Scales linear or logarithmic
- Replay function: rapid callup of history data with zoom function
- Preformatted screen display, such as horizontal or vertical curves, bar graphs, instrument display, circular chart or digital display, allow rapid and uncomplicated commissioning:

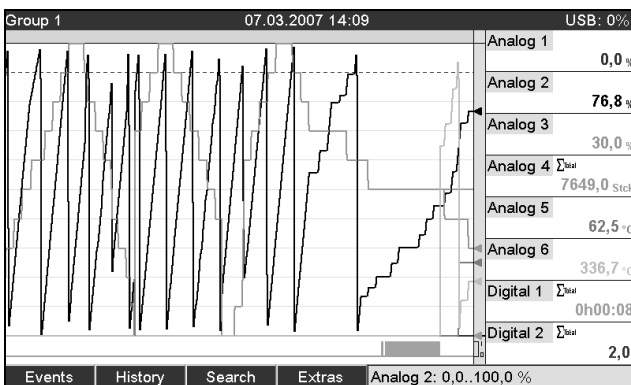

Curve display

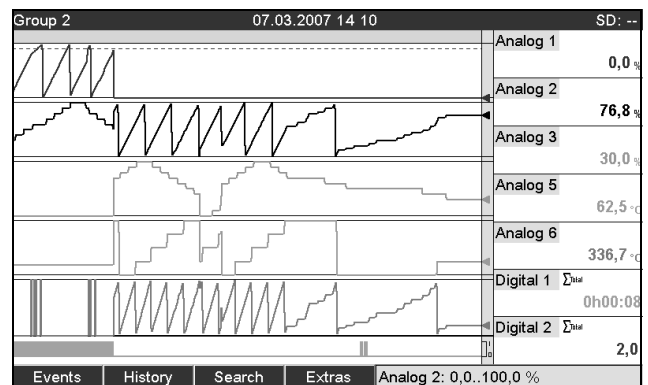

Curve in ranges

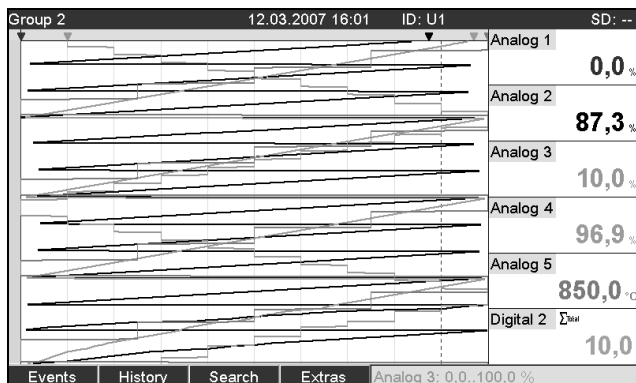

Waterfall

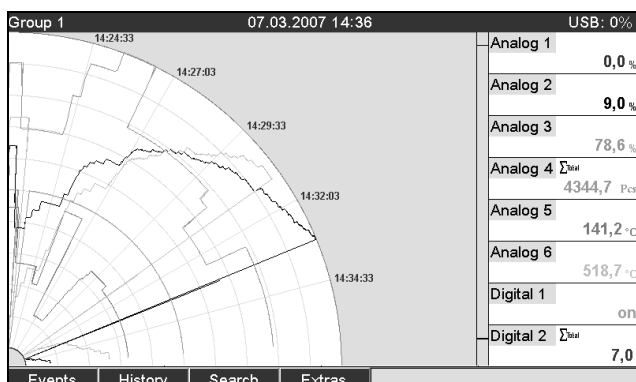

Circular chart

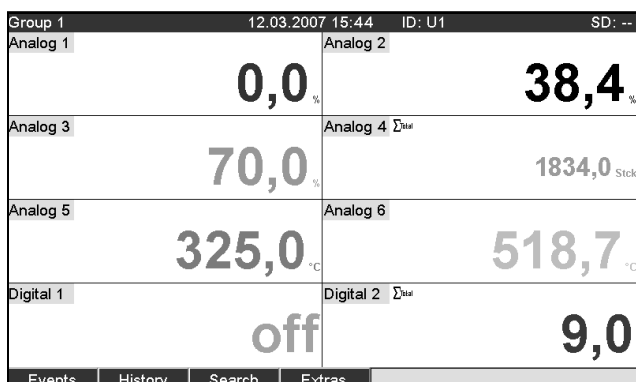

Digital display

Group 1: Event log / Audit Trail		12.03.2007 15:42	User1	SD: --
061	Setup has been changed: User1 (U1)	12.03.2007 15:41:38		
060	Firmwareupdate: GMU000A 00.00.1...	12.03.2007 15:41:30		Analog 1 0,0 %
059	Netz Ein: User1 (U1)	12.03.2007 15:41:30		Analog 2 52,8 %
058	Netz Aus: User1 (U1)	07.03.2007 15:52:33		Analog 3 50,0 %
057	Digital 1: H->L: User1 (U1)	07.03.2007 15:52:21		Analog 4 Σ <sub>max</sub> 1033,4 Stk
056	Digital 1: L->H: User1 (U1)	07.03.2007 15:52:20		Analog 5 325,0 °C
055	Digital 1: H->L: User1 (U1)	07.03.2007 15:52:18		Analog 6 982,8 °C
054	Digital 1: L->H: User1 (U1)	07.03.2007 15:52:17		Digital 1 off
053	Digital 1: H->L: User1 (U1)	07.03.2007 15:52:16		Digital 2 Σ <sub>max</sub> 9,0
052	Setup wurde geändert: User1 (U1)	07.03.2007 15:43:24		
051	Setup: Gruppe 1 geändert.: User1 (...)	07.03.2007 15:43:24		
050	Setup wurde geändert: User1 (U1)	07.03.2007 15:33:40		
049	Setup: Applikationseinst. geändert.: ...	07.03.2007 15:33:40		
048	OK: Grenzwert Digital1: User1 (U1)	07.03.2007 15:32:36		
047	Abgemeldet: User1 (U1)	07.03.2007 15:32:36		
046	Angemeldet: User1 (U1)	07.03.2007 15:32:36		

Event log

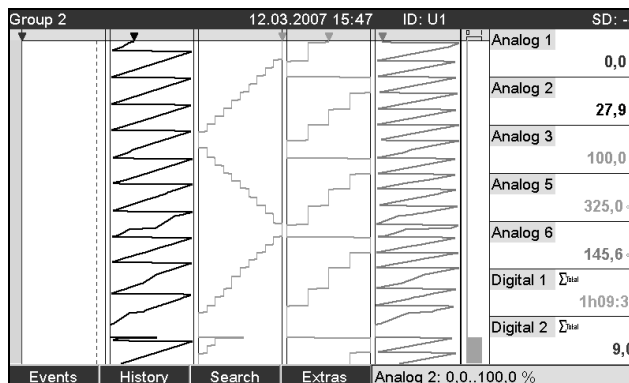

Waterfall in ranges

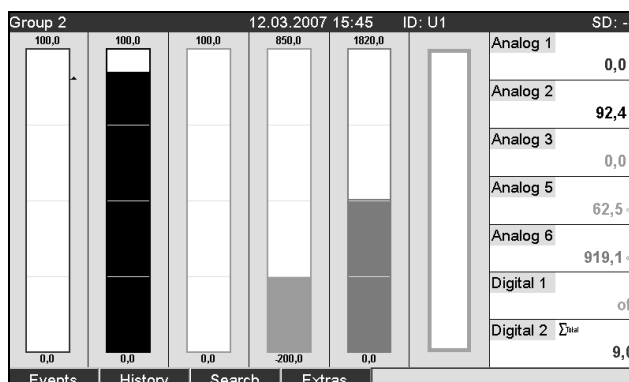

Bar graph

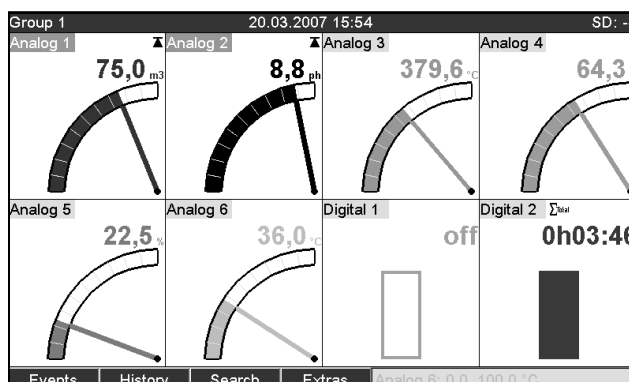

Instrument display

**Operating elements**

**Keyboard:**

Option of operation and configuration via navigator (jog/shuttle dial) and 4 softkeys on the front side in interactive dialog with the screen, or using PC software supplied. Integrated online help displayed at the press of a button.

**Data storage**

**Memory cycle:**

- Selectable memory cycle: off, 100ms, 1s / 2s / 3s / 4s / 5s / 10s / 15s / 20s / 30s / 1min / 2min / 3min / 4min / 5min / 10min / 30min / 1h
- High-speed saving (100ms) can be configured for up to 8 channels of group 1

**Measured data storage, internal memory:**

- Setup data memory, measured data memory and program memory: permanent backup of setup data and measured data in internal Flash memory with power failure protection (256 MB, nonvolatile)
- Data buffering and RTC buffering with lithium cell (replace after 10 years)
- Even after being exported to a USB stick or SD card, measured data remain in the device for a long time and can be reexported. This is important if the external data storage unit is lost or for official audits.
- Plant monitoring functions with operated hours counter, calibration monitoring, monitoring of storage medium exchange and other functions for monitoring the device status.

**External memory:**

- Cyclic copy of the measured data for archiving on SD card (secure digital memory card)
- SD cards supported: 256 MB and 512 MB. Only use "Industrial Grade" SD cards (see Accessories).
- USB sticks supported: 128 MB, 256 MB, 512 MB, 1 GB and 2 GB. It cannot be guaranteed that USB sticks of all manufacturers operate error free. Therefore an "Industrial Grade" SD card for safe data recording is recommended (see Accessories).
- A yellow LED beside the SD slot indicates data access. The SD card may not be removed while this LED is lit. Risk of losing data!

**Typical recording length:**

Prerequisites for following tables:

- No limit value violation/event storage
- Digital input not used
- Signal analysis deactivated



Note!

Frequent entries in the event log reduce the memory availability!

*Internal memory 256 MB (weeks = w, days = d, hours = h):*

Analog inputs	Memory cycle 5 min.	Memory cycle 1 min.	Memory cycle 30 s.	Memory cycle 10 s.	Memory cycle 1 s.
1	4667 w, 2 d, 23 h	1526 w, 5 d, 2 h	819 w, 4 d, 10 h	287 w, 2 d, 7 h	32 w, 2 d, 20 h
4	2156 w, 0 d, 3 h	650 w, 3 d, 1 h	345 w, 4 d, 3 h	129 w, 5 d, 5 h	12 w, 2 d, 12 h
12	35 w, 6 d, 6 h	31 w, 6 d, 5 h	27 w, 3 d, 17 h	18 w, 1 d, 0 h	3 w, 1 d, 16 h
20	22 w, 1 d, 6 h	21 w, 2 d, 3 h	17 w, 2 d, 15 h	11 w, 0 d, 19 h	1 w, 6 d, 18 h

*External SD card 256 MB (weeks = w, days = d, hours = h):*

Analog inputs	Memory cycle 5 min.	Memory cycle 1 min.	Memory cycle 30 s.	Memory cycle 10 s.	Memory cycle 1 s.
1	6274 w, 0 d, 14 h	2052 w, 1 d, 21 h	1101 w, 5 d, 10 h	386 w, 1 d, 16 h	43 w, 3 d, 22 h
4	2898 w, 1 d, 6 h	874 w, 2 d, 8 h	464 w, 3 d, 21 h	174 w, 2 d, 20 h	16 w, 4 d, 6 h

Analog inputs	Memory cycle 5 min.	Memory cycle 1 min.	Memory cycle 30 s.	Memory cycle 10 s.	Memory cycle 1 s.
12	59 w, 1 d, 9 h	52 w, 4 d, 3 h	45 w, 2 d, 20 h	29 w, 6 d, 11 h	5 w, 2 d, 9 h
20	36 w, 4 d, 1 h	35 w, 0 d, 23 h	28 w, 4 d, 14 h	18 w, 2 d, 7 h	3 w, 1 d, 17 h

#### Calculating the recording duration:

The recording duration is calculated using the "storage calculator" (can be found in the "Tools" directory on the PC software CD-ROM supplied - pending).

#### Real time clock (RTC)

Configurable summer time/normal time automated system  
 Power reserve: buffering via lithium battery  
 Deviation: < 10 min./year  
 Time synchronization possible via PC software supplied or via control input.

#### Remote control, communication

- USB interface, series (front-panel), Ethernet interface and additional RS232/RS485 interface optional (rear)
- OPC server (3.0) for direct data exchange with databases or/and visualization systems
- Integrated Internet page (Web server) allows password-protected access to the device with every PC (e.g. for displaying the measured data)
- DHCP-enabled (dynamic allocation of an IP address)
- Device-internal summer time/winter time changeover
- Configuring and archiving the device settings with SD card, USB stick or with PC software supplied via rear-mounted serial interface RS232/RS485 (e.g. modem), Ethernet, or USB port.

Functions of the PC software supplied:

- Device configuration, measured data visualization, measured data administration and measured data export
- Export the measured data of individual channels to separate files or several channels to one file

## Certificates and approvals

#### CE mark

The measuring system meets the legal requirements of the EC directives. The manufacturer confirms successful testing of the device by affixing the CE mark.

#### UL-listed for Canada and USA

The device has been examined by Underwriters Laboratories Inc. (UL) in compliance with the UL 61010-1 and CSA C22.2 No. 61010-1 standards and has been UL-listed under the number E225237 (pending).

#### Other standards and guidelines

CSA approval  
 CAN/CSA-C22.2 No. 61010-1-04 Safety requirements for electrical equipment for measurement, control, and laboratory use - General requirements, Second Edition (pending).

#### Electronic recording/ electronic signature

FDA 21 CFR11  
 The device meets the requirements of the "Food and Drug Administration" for electronic recording/electronic signature.

## Ordering information

### Product structure

<b>Basic features:</b>										
7" TFT color graphic display, 800 x 480 pixels										
256 MB internal memory										
Security package: person-specific access authorization and electronic signature (FDA 21 CFR 11)										
Interactive dialog operation with navigator and 4 operating keys										
24 V auxiliary output voltage										
100 limit values										
Integration, signal evaluation										
Secure digital SD slot										
<b>Signal input</b>										
<b>A</b>		Not selected								
<b>B</b>		4 multifunctional inputs (U, I, TC, RTD, pulse/frequency input 10 kHz)								
<b>C</b>		8 multifunctional inputs (U, I, TC, RTD, pulse/frequency input 10 kHz)								
<b>D</b>		12 multifunctional inputs (U, I, TC, RTD, pulse/frequency input 10 kHz)								
<b>E</b>		16 multifunctional inputs (U, I, TC, RTD, pulse/frequency input 10 kHz)								
<b>F</b>		20 multifunctional inputs (U, I, TC, RTD, pulse/frequency input 10 kHz)								
<b>Digital input; output</b>										
<b>1</b>		6 x digital, 25 Hz; 6 x relay, 1 x SPDT + 5 x SPST								
<b>2</b>		14 x digital, 25 Hz; 12 x relay, 1 x SPDT + 11 x SPST, 2 x analog output								
<b>Power supply</b>										
<b>1</b>		115/230 V AC, 50/60 Hz								
<b>2</b>		24 V AC/DC, 50/60 Hz								
<b>Communication</b>										
<b>1</b>		Not selected								
<b>2</b>		Profibus DP slave, max. 40 x analog, 14 x digital								
<b>3</b>		Modbus RTU, max. 40 x analog, 14 x digital								
<b>4</b>		Modbus TCP, max. 40 x analog, 14 x digital (not for modem)								
<b>Interface</b>										
<b>A</b>		1 x USB function (front), 1 x USB host (front)								
<b>B</b>		1 x USB function (front), 1 x USB host (front), Ethernet, RS232/485, 2 x USB host (rear)								
<b>Factory calibration certificate</b>										
<b>1</b>		Not required								
<b>2</b>		Required								
<b>Memory medium</b>										
<b>A</b>		without SD card								
<b>B</b>		SD card 256 MB								
<b>C</b>		SD card, 512 MB								
<b>Housing</b>										
<b>1</b>		Panel 144 x 190 mm (5.67 x 7.48"), IP65, NEMA 4								
<b>2</b>		Table version, shockproof connector								
<b>3</b>		Table version, US connector								
<b>4</b>		Table version, Swiss connector								
<b>5</b>		Field housing, IP65, NEMA 4x								
<b>Operation Language</b>										
<b>A</b>		Central/western Europe (German, English, French, Spanish, Italian, Dutch)								
<b>B</b>		Eastern European (German, English, Polish, Russian, Czech)								
<b>C</b>		America (German, English, French, Spanish, Portugese)								
<b>D</b>		Asia (German, English, Japanese, Chinese, Korean)								
<b>Software</b>										
<b>1</b>		Basic version incl. security package								
<b>2</b>		Mathematics package incl. security package								
<b>Version</b>										
<b>A</b>		Standard								
<b>Approval</b>										
<b>1</b>		Non-hazardous area								
RSG40-								<b>A</b>	<b>1</b>	⇐ <b>Order code</b>

## Accessories

### Scope of delivery

- Device (with terminals, as per your order)
- 2 fastening clips
- USB cable, length 1.5 m (4.9 ft)
- Optional secure digital (SD) card (card not in device but is supplied.)
- PC operating and configuration software on CD-ROM
- Delivery note
- Multilanguage Brief Operating Instructions as hard copy
- Multilanguage Operating Instructions on CD-ROM

Anything missing? Then please inform your supplier.

### Accessories

The following accessories are available:

Order code	Accessory
RSG40A-CA	Profibus DP-slave module (for extension slot rear panel)
RSG40A-CB	Modbus RTU module (for extension slot rear panel)
RSG40A-CC	Modbus TCP module (for extension slot rear panel)
71007465	Cable USB-A - USB-B, 2 m (6.6 ft)
71038635	"Industrial Grade" SD memory card 256 MB
71044060	"Industrial Grade" SD memory card 512 MB
RSG40A-S3	RS232/RS485 adapter set 230 VAC, compact housing, without galvanic isolation
RSG40A-S5	RS232/RS485 adapter set 115 VAC, compact housing, without galvanic isolation
RSG40A-S6	RS232/RS485 adapter set, DIN rail 230 VAC, with galvanic isolation + interface cable for PC/modem
RSG40A-S7	RS232/RS485 adapter set, DIN rail 115 VAC, with galvanic isolation + interface cable for PC/modem
RXU10-A1	Cable set for connection PC or modem, standard
RSG40A-H1	Field housing, IP65/NEMA 4x <div style="text-align: center;"> </div>

## Documentation

- Recording technology brochure (FA014R/09/en)
- Innovation brochure (IN005R/09/en)
- Operating Instructions (BA247R/09/en)
- Brief Operating Instructions (KA248R/09/)



---

## Instruments International

Endress+Hauser  
Instruments International AG  
Kaegenstrasse 2  
4153 Reinach  
Switzerland

Tel. +41 61 715 81 00  
Fax +41 61 715 25 00  
[www.endress.com](http://www.endress.com)  
[info@ii.endress.com](mailto:info@ii.endress.com)

**Endress+Hauser**   
People for Process Automation